

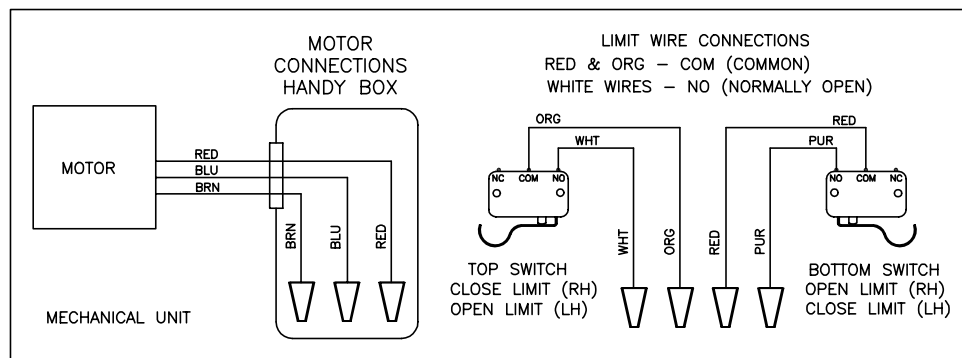

DATE	REV	REVISION NOTES	ECO	BY
5-18-00	A	RELEASED TO DOCUMENT CONTROL		CPC
6-10-03	B	GREEN LIMIT WIRE CHANGED TO PURPLE	2259	CPC

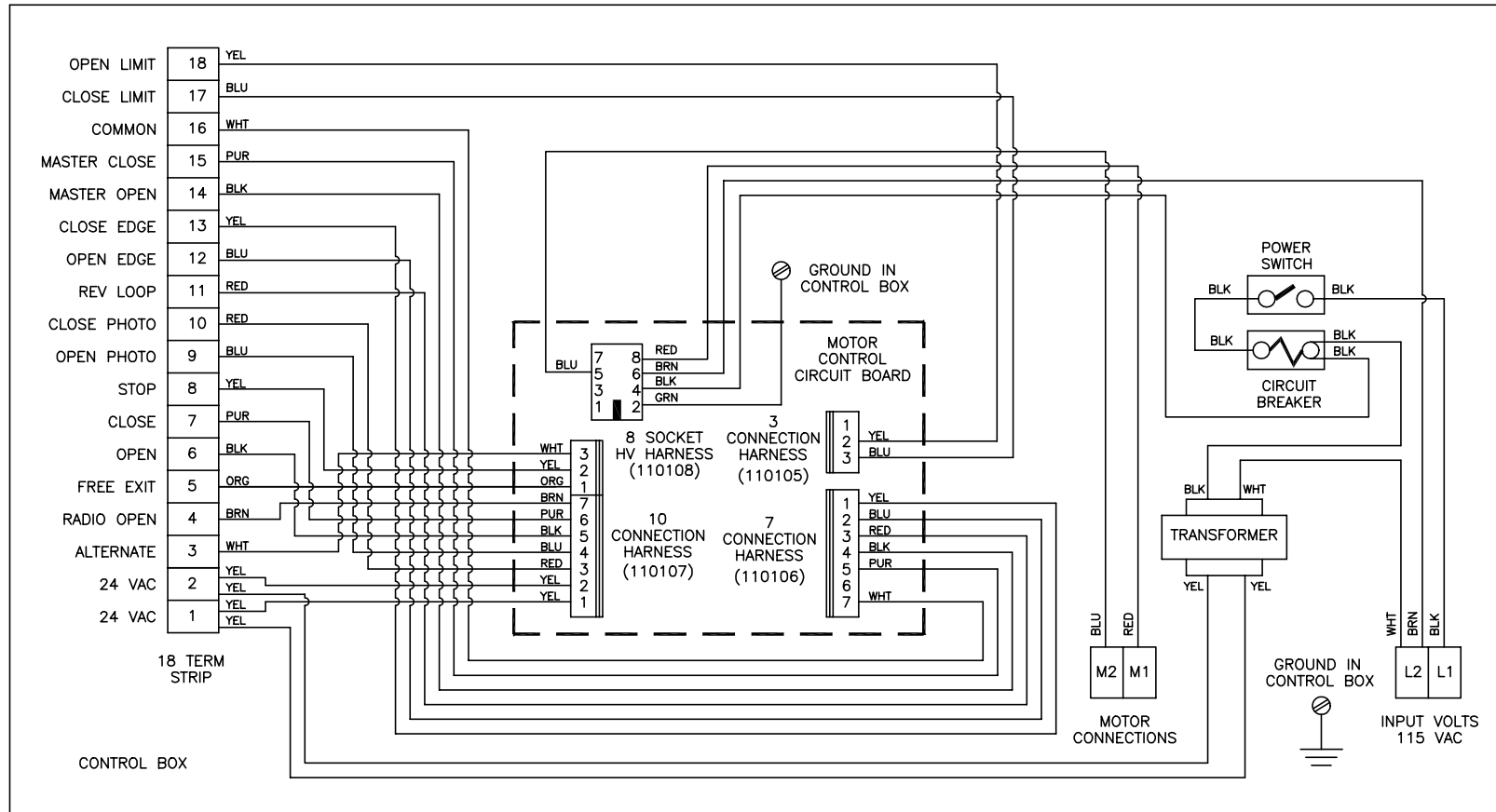

TOLERANCE (EXCEPT AS NOTED) DECIMAL X.X ±0.030 X.XX ±0.020 X.XXX ±0.010		 c.p. ALLSTAR CORPORATION PO Box 240 Downingtown, PA 19335	
FRACTIONAL ±1/32	APPROVED BY		
ANGULAR ±1°	MATERIAL N/A	DATE 5/18/00	
TITLE WIRE DIAG,HDSWG/GS4000,CGA2K		SHT 1 OF 1 © 2000	
		DWG NO. 110104	
		REV —	