



**HS91 Series**

**Thermo-Electric Cooled Housings**

**Aigis Mechtronics, Inc.**  
Now Part of Linear LLC  
1950 Camino Vida Roble, Suite 150  
Carlsbad, CA 92008  
Phone 800-421-1587  
[www.linearcorp.com](http://www.linearcorp.com)

## IMPORTANT SAFEGUARDS

1. Read Instructions - All the safety and operating instructions should be read before the unit is operated.
2. Retain Instructions - The safety and operating instructions should be retained for future reference.
3. Heed Warnings - All warnings on the unit and in the operating instructions should be adhered to.
4. Follow Instructions - All operating and use instructions should be followed.
5. Cleaning - Unplug the unit from the outlet before cleaning. Do not use liquid cleaners or aerosol cleaners. Use a damp cloth for cleaning.
6. Attachments - Do not use attachments not recommended by the product manufacturer as they may cause hazards.
7. Accessories - Do not place this unit on an unstable stand, tripod, bracket, or mount. The unit may fall, causing serious injury to a person and serious damage to the unit. Use only with a stand, tripod, bracket, or mount recommended by the manufacturer or sold with the product.
-  Any mounting of the unit should follow the manufacturer's instructions and should use a mounting accessory recommended by the manufacturer.  
An appliance and cart combination should be moved with care. Quick stops, excessive force, and uneven surfaces may cause the appliance and cart combination to overturn.
8. Ventilation - Openings in the enclosure, if any, are provided for ventilation, to ensure reliable operation of the unit, and to protect it from overheating. These openings must not be blocked or covered. This unit should not be placed in a built-in installation unless proper ventilation is provided or the manufacturer's instructions have been adhered to.
9. Power Sources - This unit should be operated only from the type of power source indicated on the marking label. If you are not sure of the type of power supply you plan to use, consult your appliance dealer or local power company. For units intended to operate from battery power or other sources, refer to the operating instructions.
10. Grounding or Polarization - This unit may be equipped with a polarized alternating-current line plug (a plug having one blade wider than the other). This plug will fit into the power outlet only one way. This is a safety feature. If you are unable to insert the plug fully into the outlet, try reversing the plug. If the plug should still fail to fit, contact your electrician to replace your obsolete outlet. Do not defeat the safety purpose of the polarized plug. Alternatively, this unit may be equipped with a 3-wire grounding-type plug, a plug having a third (grounding) pin. This plug will only fit into a grounding-type power outlet. This is a safety feature. If you are unable to insert the plug into the outlet, contact your electrician to replace your obsolete outlet. Do not defeat the safety purpose of the grounding-type plug.
11. Power Cord Protection - Power supply cords should be routed so that they are not likely to be walked on or pinched by items placed upon or against them, paying particular attention to cords and plugs, convenience receptacles, and the point where they exit from the appliance.
12. Power Lines - An outdoor system should not be located in the vicinity of overhead power lines or other electric light or power circuits or where it can fall into such power lines or circuits. When installing an outdoor system, extreme care should be taken to keep from touching such power lines or circuits as contact with them might be fatal. U.S.A. models only - refer to the National Electrical Code Article 820 regarding installation of CATV systems.
13. Overloading - Do not overload outlets and extension cords as this can result in a fire or electric shock.
14. Object and Liquid Entry - Never push objects of any kind into this unit through openings, as they may touch dangerous voltage points or short out parts that could result in a fire or electric shock. Never spill liquid of any kind on the unit.
15. Servicing - Do not attempt to service this unit yourself as opening or removing covers may expose you to dangerous voltage or other hazards. Refer all servicing to qualified service personnel.
16. Damage Requiring Service - Unplug the unit from the outlet and refer servicing to qualified service personnel under the following conditions:
  - a. When the power supply cord or plug is damaged.
  - b. If liquid has been spilled or objects have fallen into the unit.
  - c. If the unit has been exposed to rain or water.
  - d. If the unit does not operate normally by following the operating instructions. Adjust only those controls that are covered by the operating instructions, as an improper adjustment of other controls may result in damage and will often require extensive work by a qualified technician to restore the unit to its normal operation.
  - e. If the unit has been dropped or the cabinet has been damaged.
  - f. When the unit exhibits a distinct change in performance--this indicates a need for service.
17. Replacement Parts - When replacement parts are required, be sure the service technician has used replacement parts specified by the manufacturer or have the same characteristics as the original part. Unauthorized substitutions may result in fire, electric shock, or other hazards.
18. Safety Check - Upon completion of any service or repairs to this unit, ask the service technician to perform safety checks to determine that the unit is in proper operating condition.
19. Coax Grounding - If an outside cable system is connected to the unit, be sure the cable system is grounded. U.S.A. models only--Section 810 of the National Electrical Code, ANSI/NFPA No.70-1981, provides information with respect to proper grounding of the mount and supporting structure, grounding of the coax to a discharge unit, size of grounding conductors, location of discharge unit, connection to grounding electrodes, and requirements for the grounding electrode.
20. Lightning - For added protection of this unit during a lightning storm, or when it is left unattended and unused for long periods of time, unplug it from the wall outlet and disconnect the cable system. This will prevent damage to the unit due to lightning and power line surges.

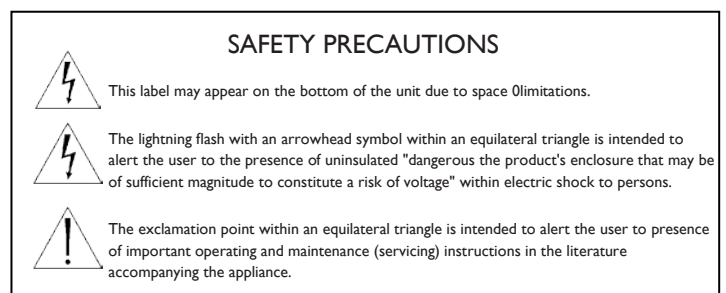
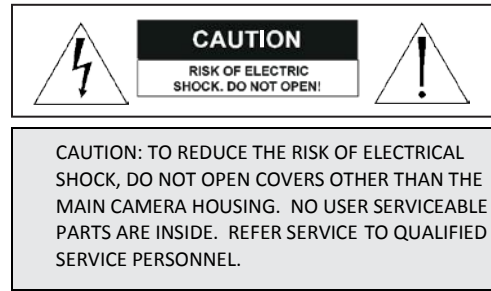

# Thermo-Electric Cooled (TEC) Housing

## Description

HS91-6x Series camera housings are designed with an integrated Thermo-Electric Cooling module. The housings operate on 110VAC and include a pass-through data connection for IP cameras. Both models allow the user to power the camera with Power-over-Ethernet (PoE) via the network cable, and include a Fault Alarm which will alert the user if the cooling unit fails.

- The HS91-63THIPC model includes additional features including a pass-through power connection to power the camera (or other device) instead of a PoE supply. In addition to the Fault Alarm, this unit includes a Tamper Alarm that alerts when the housing is opened.

## Models

HS91-6ETHIPC	Thermo-Electric Cooled housing, IP-ready, with heater, blower, tamper switch circuit, fault alarm, includes sunshield
HS91-6TEC	Thermo-Electric Cooled housing, IP-ready, with heater, blower, fault alarm, includes sunshield.
MT9235	Mount Kit Accessory, includes (1) MT9237 Heavy Duty Adjustable Head Mounting Bracket and (1) MT9222 Wall Mount.

## Electrical

HS91-6xxx	Input voltage: 110VAC ± 10%
	Power required: 80W Max

## Hardware Kit

- 3 x 1/4-20 x 3/4" Button Head Cap Screw
- 3 x 1/4" Flat Washers
- 3 x 1/4" Lock Washers
- 1 x 1/4-20 Camera Mounting Screw
- 1 x M5 Allen Wrench

### HS91-6ETHIPC:

- 1 x RJ45 Network Connector (Molex p/n 84700-0002)
- 1 x 4-pin Power Connector (AMP p/n C016 20D003 100 12)
- 1 x 7-pin Aux Power/Alarm Connector (AMP p/n C016 10D006 000 12)
- 10 x Crimp Contacts, 16 ~ 20AWG (AMP p/n VN 02 016 0002 (1))

### HS91-6TEC

- 1 x RJ45 Network Connector (Molex p/n 84700-0002)
- 1 x 4-pin Power Connector (AMP p/n C016 20D003 100 12)

## Tools Needed

- 5/32" Allen Wrench
- M5 Allen Wrench (included)
- Crescent Wrench
- Flat blade screwdriver, 0.1-in (2.5mm) or smaller
- RJ45 connector crimp tool (Belkin p/n F4F198 or similar)
- Crimp Tool (HS91-6ETHIPC Only, info below)

Tool Description	Amphenol Part Number	Digikey Part Number
Crimp Tool	TA 0000	361-1099-ND
Tool Locator	TA 0002 146 0001	361-1104-ND

## Assembly Instructions



Installation of this product must be performed by a licensed electrician, conform to the National Electrical Code (NEC), and conform to any state or local codes.

Refer to the below image (Figure 1) for component descriptions.

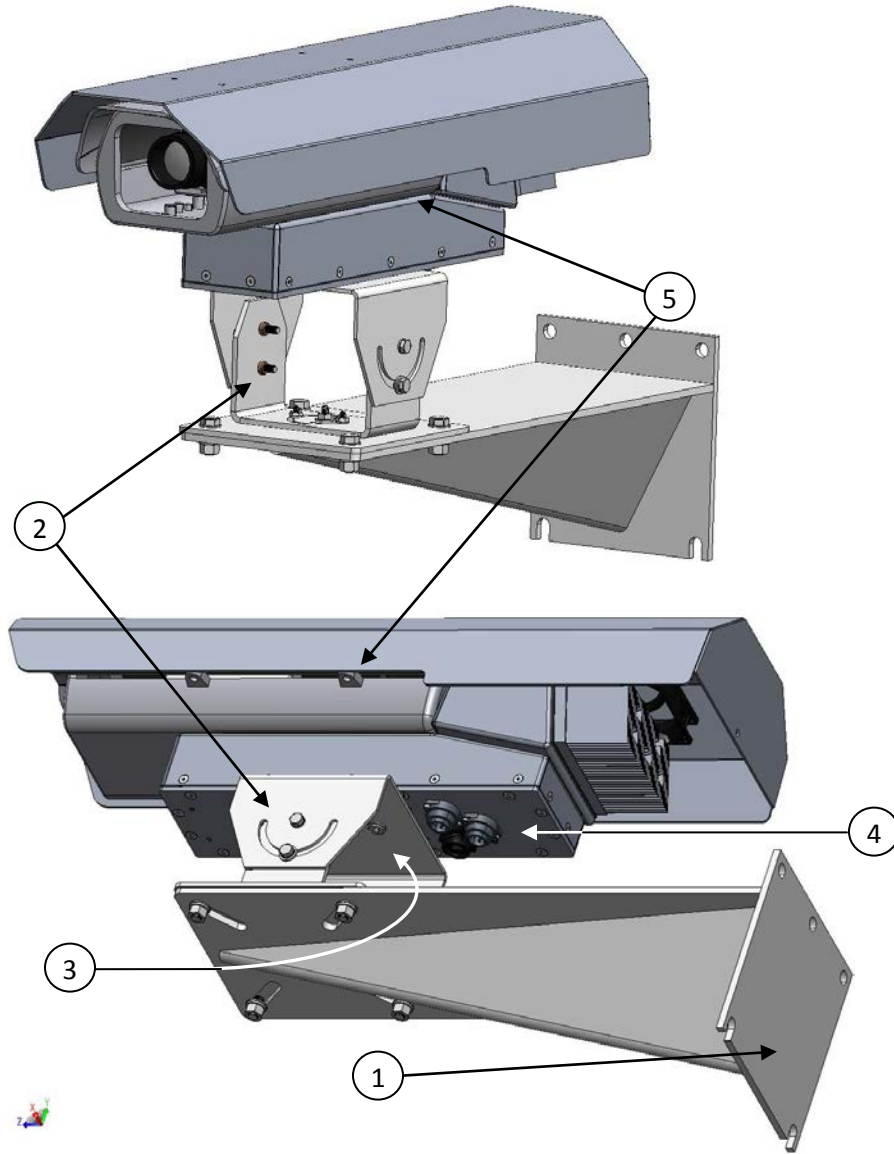

Figure 1 - Assembled Product

Item	Description	Manual Section
1	Wall Mount (MT9222)	1
2	Adjustable Head Bracket (MT9237)	2
3	Housing Attachment	3
4	Cable Connections	4
5	Accessing Camera Housing	5

## 1. Wall Mount

- 1.1. Refer to the installation manual included with the MT9222 Wall Mount.
- 1.2. Use customer-supplied fasteners to secure the wall mount to the mounting surface.
- 1.3. The bolt-hole pattern and mount dimensions are shown in Figure 2.

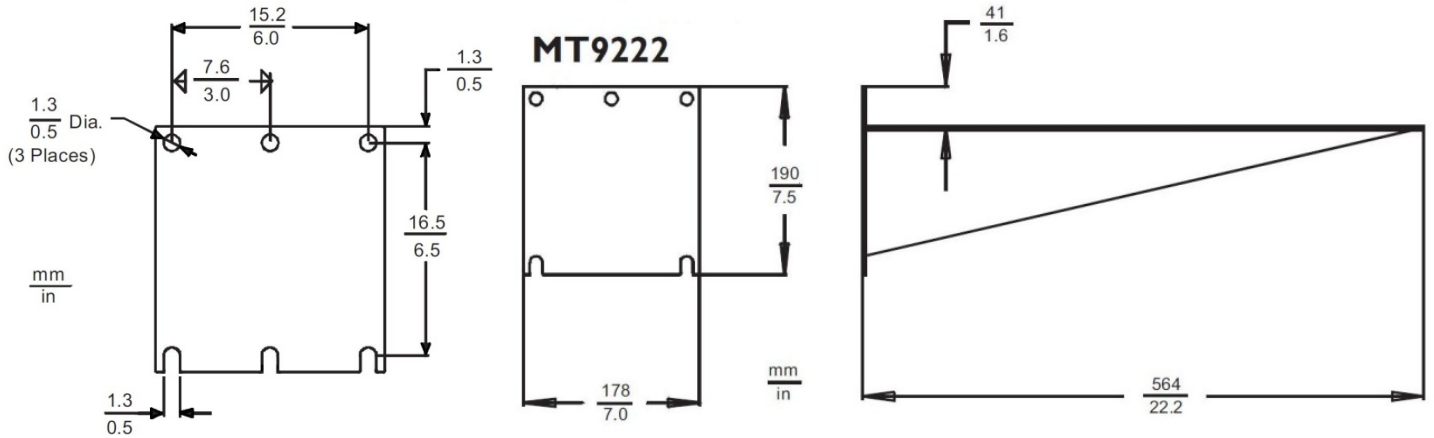

Figure 2 - Wall Mount Dimensions

## 2. Adjustable Head Bracket

- 2.1. Refer to the installation manual included with the MT9237 Heavy Duty Adjustable Head Bracket.
- 2.2. Attach the bracket to the wall mount as shown in Figure 3.
- 2.3. Four 3/8-16 Hex Head bolts (stainless) are included with the bracket. Install the hardware in the order shown in Figure 3.

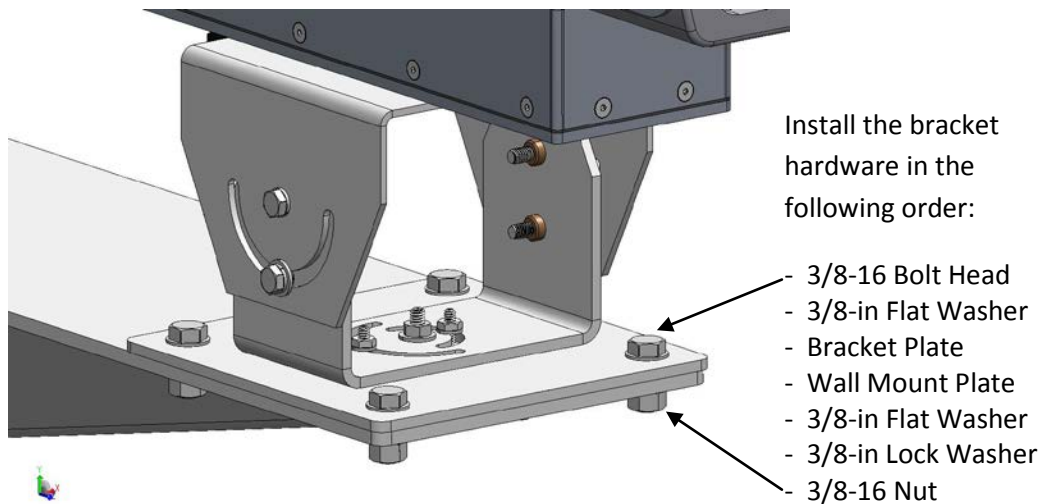

Figure 3 - Adjustable Head Bracket

### 3. Housing Attachment

- 3.1. Attach the camera housing to the bracket as shown in Figure 4.
- 3.2. The referenced fasteners are included in the hardware kit that ships with the camera housing.
- 3.3. An Allen wrench is included with the camera housing; use it to tighten the Button Head Cap Screws.

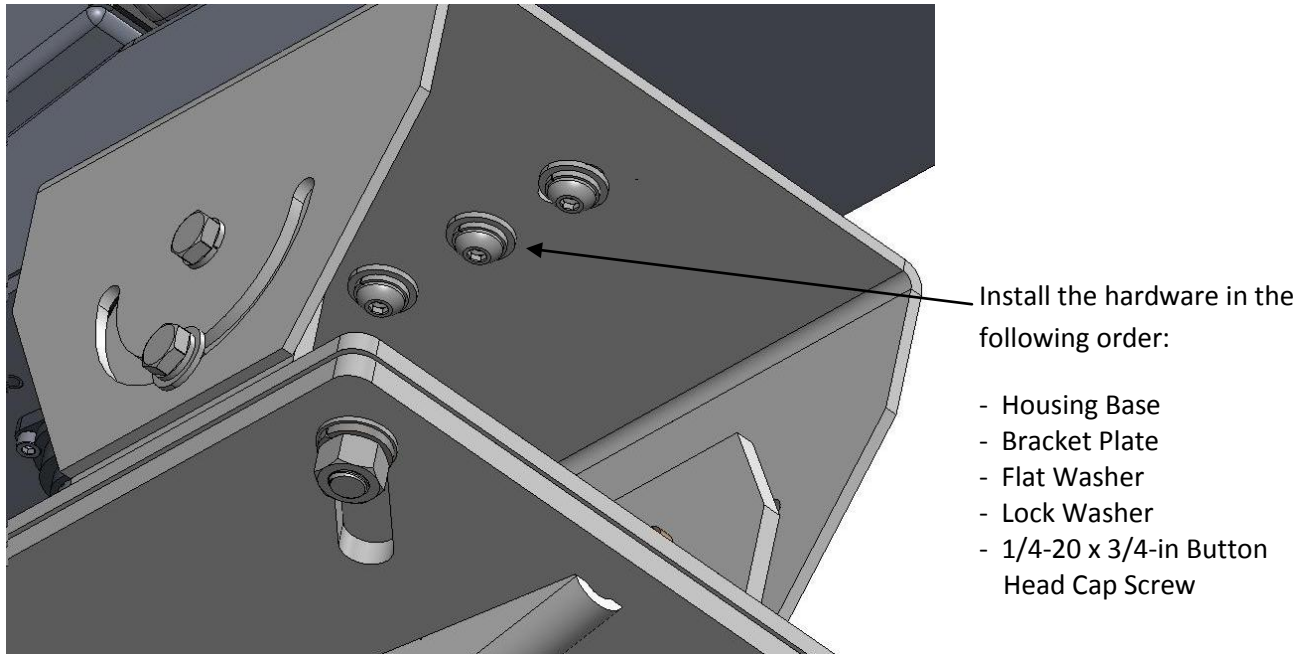

Figure 4 - Attach Camera Housing

## 4. Cable Connectors

### HS91-6ETHIPC Connectors

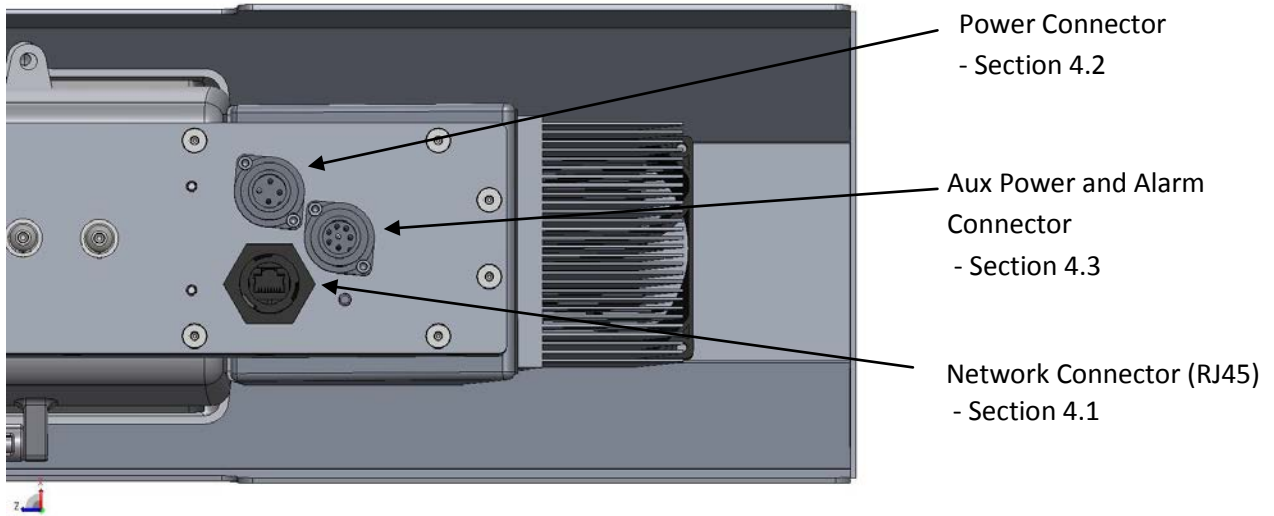

Figure 5 - HS91-6ETHIPC Connectors

### HS91-6TEC Connectors

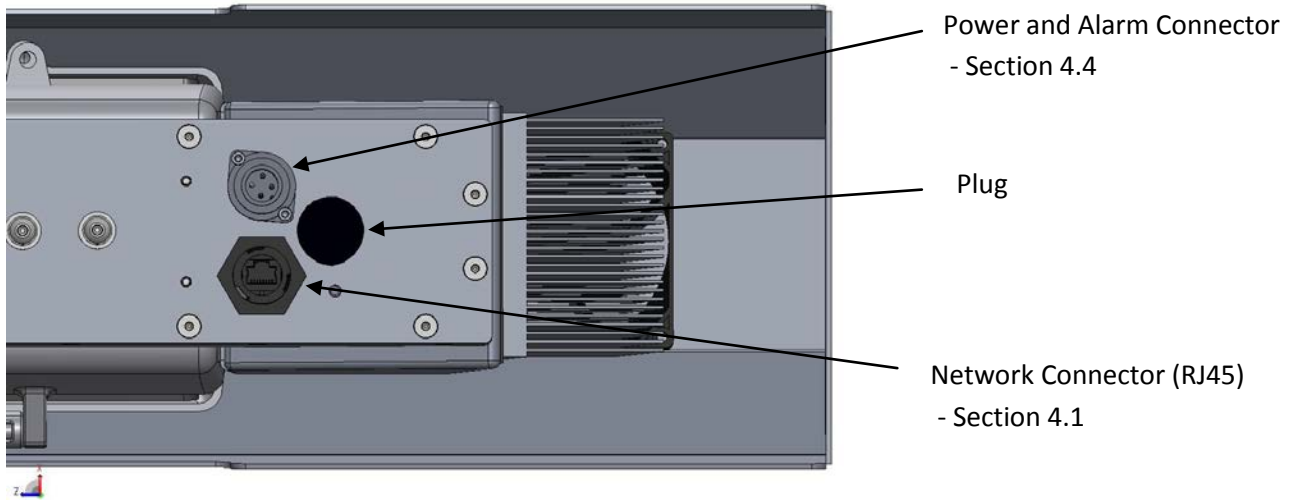

Figure 6 - HS91-6TEC Connectors

#### 4.1. Network Connector (RJ45)

Refer to Figure 7 when assembling this connector.

- 4.1.1. Run a sufficient length of network cable to the installation site such that the cable can be strain relieved and reach the connectors at the base of the housing.
- 4.1.2. Loosen the cap of Item 1. Slide the items onto the cable in the order shown. Note that items 1-4 can be pre-assembled before sliding the network cable through.
- 4.1.3. Cut back the outer network cable jacket as needed and splice the wire into the RJ45 connector (Item 7).
- 4.1.4. Close the RJ45 connector until it clips into place. Ensure the gasket (Item 6) is in place around the lip of the connector body (Item 4).
- 4.1.5. Slide the network cable back out of the connector assembly until the RJ45 connector is seated into the slot, Item 4.
- 4.1.6. Insert the retaining wedge (Item 5) into the bottom of the connector housing (Item 4) to hold the RJ45 connector in place.
- 4.1.7. Slide the bayonet ring (Item 3) forward, screw Item 1 into Item 4 (ensure the gasket is seated around the lip of Item 1).
- 4.1.8. Tighten the cap of Item 1.

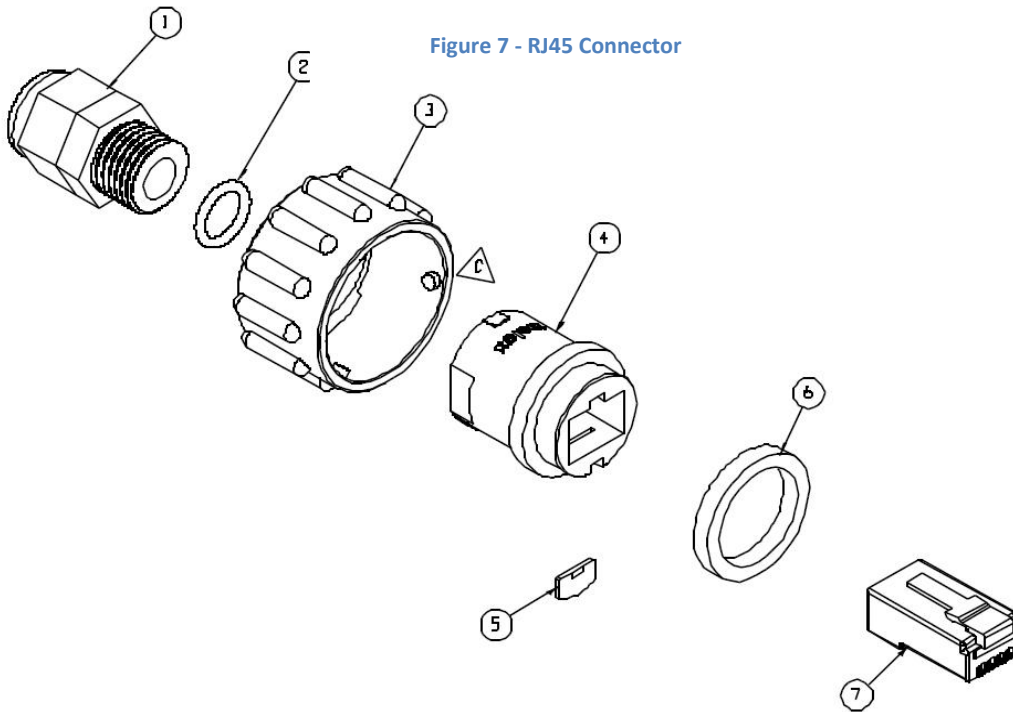

Figure 7 - RJ45 Connector

Reference No.	Description	Reference No.	Description
1	Cordgrip fitting	5	Retaining Wedge
2	Gasket	6	Gasket
3	Bayonet Lock	7	RJ45 Connector
4	Connector Housing		

4.2. **Power Connector (HS91-6ETHIPC)**

Refer to Figure 8 when assembling these connectors. **Note the connector shown (item 6) shows pin contacts in item 6. The actual cable connector uses socket contacts.**

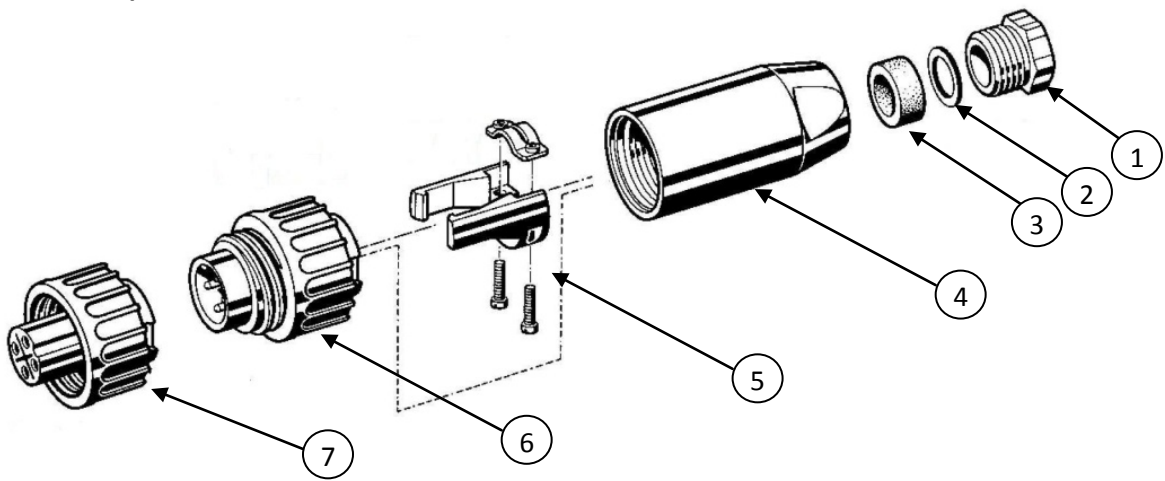
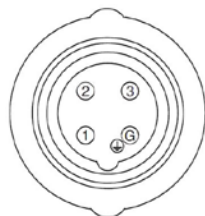

Figure 8 - Multi-Pin Connectors

Reference No.	Description	Reference No.	Description
1	Cordgrip fitting	5	Strain Relief Assembly
2	Metal washer	6	Connector Housing (Sockets)
3	Gasket	7	Connector Housing (Pins)
4	Connector Shell		

- 4.2.1. Item 7 is not included in the hardware it. The component is the connector that mates with Item 6, and is pre-installed in the base of the camera housing. It is shown here for clarity.
- 4.2.2. Assemble items 1-4 first. Slide the assembly up the power cord.
- 4.2.3. Two gaskets (Item 3) are included. One accept 6-9mm (0.230-0.350-in) diameter cables, the other accepts 9-12.5mm (0.350-0.490-in) diameter cables.
- 4.2.4. Using a small flat-blade screwdriver, terminate the power wires into the connector according to the pin designation in Figure 9.
- 4.2.5. Construct the strain relief assembly (Item 5) around the cable such that the arms of the assembly can clip into connector housing (Item 6) to provide strain relief.
- 4.2.6. Slide the remainder of the connector (Items 1-4) down the wire and screw the assembly into the back of the connector housing.
- 4.2.7. Tighten the cordgrip until the connector is securely fastened to the cable.



**Power Connector ( HS91-6ETHIPC)**

Pin Number	Designation
1	110VAC Line
2	Not Connected
3	110VAC Neutral
G	Earth Ground

Figure 9 - HS91-6ETHIPC Power Connector

### 4.3. Aux Power and Alarm Connector (HS91-6ETHIPC)

- 4.3.1. This connector is similar in construction to the connector in the previous section. The primary differences are that this connector includes seven (7) connections, and terminating the wires into the connector requires a crimp tool and crimp contacts.
- 4.3.2. Two gaskets (Item 3 from Figure 8) are also included with this connector. One gasket accept 6-9mm (0.230-0.350-in) diameter cables, the other accepts 9-12.5mm (0.350-0.490-in) diameter cables.
- 4.3.3. The hardware kit includes ten (10) crimp contacts. The part number of the crimp tools and contacts is listed in the Tools Needed section.
- 4.3.4. Refer to the manual included with the crimp tool to terminate the cables properly.
- 4.3.5. Pin the connector according to Figure 10.
- 4.3.6. Construct the connector according to the instructions in Section 4.2

**Power Connector ( HS91-6ETHIPC)**

Pin No.	Designation	Pin No.	Designation
1	24VAC	5	Tamper Alarm - Common
2	24VAC	6	Tamper Alarm – Normally Open
3	Fault Alarm - Common	7	Housing Ground
4	Fault Alarm - Normally Open		

Figure 10 - Aux Pwr. / Alarm Connector (HS91-6ETHIPC)

### 4.4. HS91-6TEC Connector

- 4.4.1. This housing includes a single 4-pin connector that combines the power and the fault alarm.
- 4.4.2. Note that the Fault Alarm shares a circuit with Earth Ground. The Fault Alarm is a dry contact relay that is open when the housing is operating normally and closed when an error has occurred. Use appropriate surge protection when connecting the fault alarm to any equipment that could be damaged by current flowing over the ground wire.
- 4.4.3. The construction of the HS91-6TEC Power/Alarm connector is identical to the connector shown in section 4.2.
- 4.4.4. Pin the cable according to Figure 11.

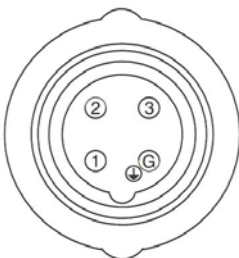

**Power/Alarm Connector**

Pin No.	Designation
1	110VAC Line
2	Fault Alarm (Normally Open)
3	110VAC Neutral
G	Earth Ground/Fault Alarm (Common)

Figure 11 - Power/Alarm Connector (HS91-6TEC)

## 5. Opening the Housing – Installing and Servicing the Camera

- 5.1. Access the camera housing by loosening the captive screws on the side of the camera housing as shown in Figure 12. Use the M5 Allen wrench from the hardware kit.
- 5.2. Loosen the four screws that hold the camera sled in place. Remove the camera sled by sliding the bracket to let the screws slip through the keyholes.
- 5.3. Attach the camera and lens to the camera sled using the 1/4-20 screw provided.
- 5.4. This housing is designed to power the camera via PoE. Alternate methods for powering the camera include:
  - 5.4.1. HS91-6ETHIPC: 24VAC flying leads are provided for camera power (requires external 24VAC supply)
  - 5.4.2. HS91-6TEC: 12VDC flying leads are provided for camera power up to 1.0A. Be sure to test the wires for polarity before plugging in the camera.

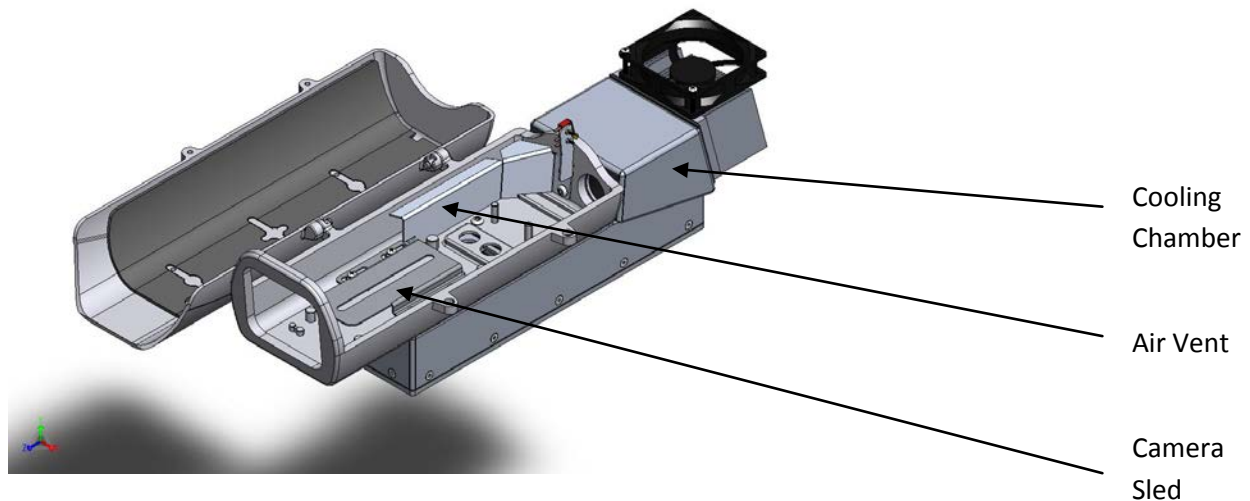

## 6. Supplemental Information

### 6.1. Alarm Wiring

Both the Tamper Alarm and the Fault Alarm circuits with dry contact relays.

- 6.1.1. The Tamper Alarm is in an open state when the housing lid is closed. The circuit is closed when the housing lid is lifted allowing access to the camera.
- 6.1.2. The Fault Alarm is in an open state when the unit is operating normally. The circuit is closed when the temperature inside the housing exceeds 70°C (158°F).

### 6.2. Heating/Cooling Information

- 6.2.1. Both HS91 models include the same Thermo-Electric Cooling (TEC) module. The circuit can be run in forward or reverse modes, meaning the TEC module can heat or cool the inside of the housing.
- 6.2.2. A thermostat inside the housing measure the temperature and drives the TEC circuit accordingly. Refer to the table below for additional information.

Temperature	TEC Mode	Temperature	TEC Mode
>35°C (95°F)	High Power Cooling	>22°C (71°F)	Heater (non-TEC) Idle
>30°C (86°F)	Low Power Cooling	<20°C (68°F)	Heater (non-TEC) Engages
<29°C (84°F)	TEC System Idle	< 5°C (41°F)	TEC Heating Engages



1950 Camino Vida Roble, Suite 150  
Carlsbad, CA 92008  
Tel: 760.438.7000 800.421.1587  
[www.aigismech.com](http://www.aigismech.com) • [www.linearcorp.com](http://www.linearcorp.com)

100 0285 002 AIG 12/11  
Printed in the U.S.A.