

Allister

DOOR CONTROL SYSTEMS

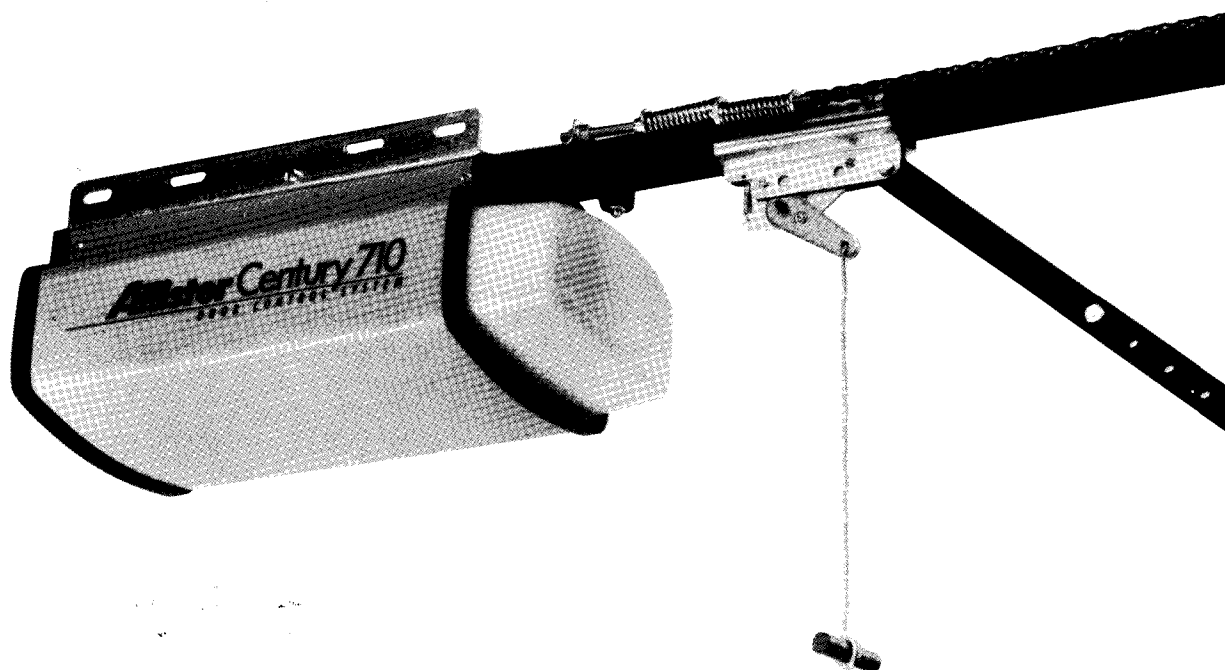

TABLE OF CONTENTS

<u>SECTION</u>	<u>PAGE</u>
FEATURES & OPERATION	2
COMPONENT IDENTIFICATION	3
REQUIRED TOOLS	3
ASSEMBLY INSTRUCTION	4
INSTALLATION CAUTIONS	5
DOOR IDENTIFICATION	5
INSTALLATION INSTRUCTIONS	6
RADIO CODING & OPERATION	9
TROUBLESHOOTING GUIDE	10
WIRING SCHEMATIC	11
INSTALLATION CHECKLIST	12

**Residential
Operators
Radio Controls &
Related
Accessories**

**Assembly &
Installation
Guide**

ALLISTER DOOR CONTROL SYSTEMS

Product Features & Installation Preparations

The purpose of this booklet is to provide assembly, installation and operation information concerning Allister Century Series garage door operators and related accessory products.

IT IS IMPORTANT THAT THIS INSTRUCTION MANUAL BE READ AND UNDERSTOOD COMPLETELY BEFORE INSTALLATION OR OPERATION ARE ATTEMPTED.

STANDARD FEATURES:

Time-Delay Light: The operator light comes on when the operator is started in the "open" direction. It remains lit for 4-1/2 minutes after the door has opened, allowing ample time to enter or exit the garage. When closing the door, Allister's exclusive Close Alert™ circuitry causes the light to flash twice to signal that the door is about to close. Again, the light remains on for 4-1/2 minutes after the door has closed. (P. 8)

Sensing System: A built-in sensing system detects obstructions during door operation. If in the downward (close) travel mode, the operator will sense an obstruction and reverse the direction of the door. In the open mode, the operator will stop. Since all doors are different, the Sensing System has independent adjustments for customizing the level of force required for the normal opening and closing of specific doors. (P. 8)

Snow Switch: In winter months it's common for small pieces of ice or packed snow to be trapped under the door. Ground swelling can also effect the down limit setting of the operator. Allister's Snow Switch overrides the Sensing System during the last one inch of closing travel and prevents the door from reversing if it encounters an obstruction at this point. (P. 9)

Emergency Release: A pull cord allows separation of the drive mechanism and manual operation of the door when desired, as in the event of a power failure. (P. 7)

Automatic Reconnection: Once power is restored, or automatic operation of the door is again desired, initiating operation in the normal manner (pushbutton, radio control, etc.) will effect automatic reconnection of the emergency release mechanism. (P. 7)

Digital Radio Controls: From 512 to 19,683 personal codes are possible (depending upon model purchased) with Allister's stylish radio controls. Coding switches can be easily changed in seconds without tools. Bright transmitter LED's indicate operation and monitor battery condition. (P. 9)

OPTIONAL EQUIPMENT:

Deluxe Wall Station: A replacement for the standard wall pushbutton, the Allister Plus Deluxe Wall Station features two backlit pushbuttons. One controls door operation in the normal manner while the other allows independent control of the operator light. An additional "Off-On" Security Switch prevents unwanted operation of the door from radio controls or any pushbutton control station.

Keyless Entry System: A tamperproof outdoor keypad, the Allister Plus Keyless Entry System features 10 Billion possible security codes. Easily programmable, it accommodates two separate access codes of from 3-10 digits. Lighted pushbuttons enhance nighttime use.

IMPORTANT INFORMATION & SAFETY TIPS:

Allister Century Series garage door operators are designed and tested to work on doors **WHICH ARE IN GOOD WORKING CONDITION AND PROPERLY BALANCED**. To prevent bodily injury or door damage you must adhere to all of the instructions in this manual. Before attempting installation or operation, please read this manual carefully and completely.

WARNING: YOUR GARAGE DOOR IS THE LARGEST MOVING OBJECT IN YOUR HOUSE, AND THE SPRINGS, PULLEYS, CABLES AND MOUNTING HARDWARE UTILIZED TO BALANCE ITS OPERATION ARE UNDER EXTREME TENSION AT ALL TIMES AND CAN CAUSE SERIOUS PERSONAL INJURY, EVEN DEATH, IF DISTURBED. DO NOT ATTEMPT ADJUSTMENT. CALL AN EXPERIENCED SERVICE PERSON TO MOVE, LOOSEN OR ADJUST DOOR SPRINGS OR HARDWARE.

ASSEMBLY & INSTALLATION CAUTIONS:

- Do not wear rings, watches or loose clothing while installing or servicing garage door operators. Wear safety goggles or other protective eyewear.
- Lubrication of all door hinges, pivot points, rollers and other moving parts is important for proper door operation. Use silicon spray or a lightweight oil.
DO NOT USE GREASE OF ANY KIND.
- **REMOVE ANY ROPES CONNECTED TO THE GARAGE DOOR BEFORE STARTING INSTALLATION. FAILURE TO DO SO MAY RESULT IN SERIOUS PERSONAL INJURY OR DEATH FROM ENTANGLEMENT.**

- Disengage or remove the existing lock bars on the garage door to avoid damage to the door, jamb, or operator. A properly installed door operator will hold the door firmly closed.

- Lightweight fiberglass, aluminum and steel doors will require reinforcement braces on their top sections to avoid damage and to insure proper operation of the safety reverse system.

- CHECK LOCAL BUILDING & ELECTRICAL CODES FOR MANDATORY INSTALLATION & WIRING REQUIRMENTS.** To avoid risk of shock, connect power cord only to a properly grounded outlet. If permanent wiring is required by codes, disconnect power at fuse box before attempting any wiring connections.

- The sensitivity adjustments must be set firmly enough to allow the door to operate, but not so firmly as to prevent the door from reversing or stopping on contact with an obstruction. These adjustments should be tested monthly using the procedures outlined in this manual.

FAILURE TO PROPERLY ADJUST AND REGULARLY TEST THIS SYSTEM MAY RESULT IN SERIOUS PERSONAL INJURY OR DEATH FROM ENTRAPMENT.

A GARAGE DOOR OPERATOR IS NOT A TOY. NEVER ALLOW ANYONE, ESPECIALLY CHILDREN, TO PLAY WITH AN ELECTRICALLY OPERATED DOOR, OR TO PLAY IN THE AREA OF THE DOOR. MISUSE MAY RESULT IN SERIOUS PERSONAL INJURY OR DEATH.

COMPONENT IDENTIFICATION

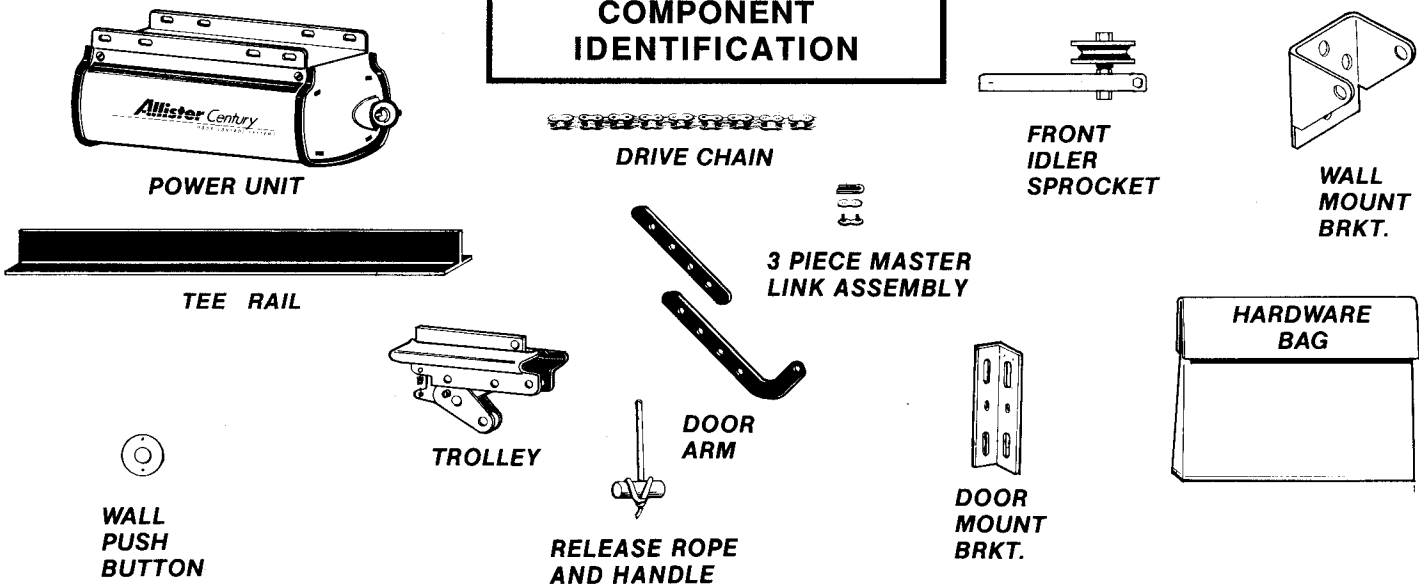

TOOLS REQUIRED FOR ASSEMBLY & INSTALLATION

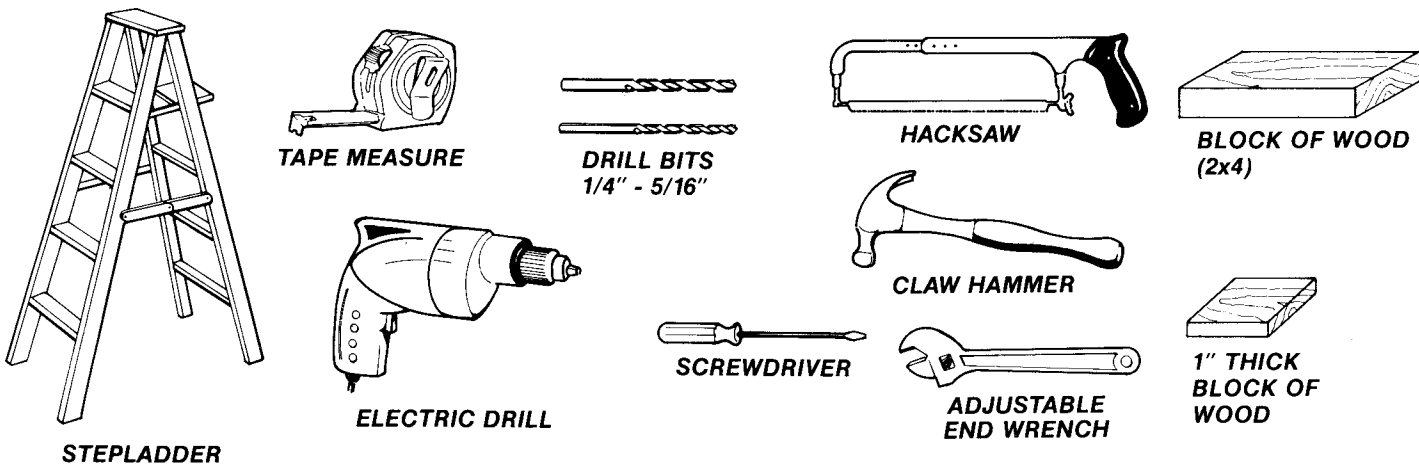

ASSEMBLY INSTRUCTIONS

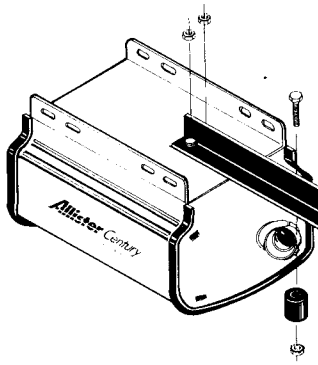

Step 1: Protect the Power Unit cover from scratching during assembly by placing it on cardboard. Attach the Tee Rail to the Power Unit with two 5/16"-18 washed nuts.

Step 2: Slide the Trolley onto the Tee Rail making sure the chain tension bracket faces toward the Power Unit.

Step 3: Attach the Front Idler Assembly and the rubber bumper to the Tee Rail with three 5/16" - 18 X 1" bolts and washered nuts.

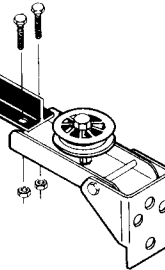

Step 4: Position the Trolley so that it is about 6" from the Front Idler Assembly. Keeping the chain rolled and flat, carefully unroll one end and using a master link connect it to the the threaded rod attached to the Trolley. Check the chain to ensure that there are no twists or kinks.

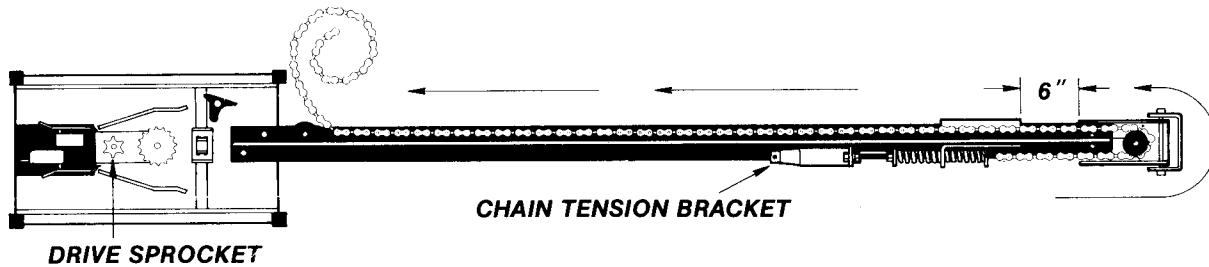

Loop the chain around the front idler wheel and unroll it towards the Power Unit, continuing to check for kinks and twists. Loop it around the Power Unit drive sprocket and back to the chain tension bracket attached to the Trolley. Connect the end of the chain to the chain tension bracket with the remaining master link assembly. After double checking chain alignment with drive sprocket and front idler wheel, use the two adjusting nuts on the threaded rod to tighten the chain to the proper tension (no droop).

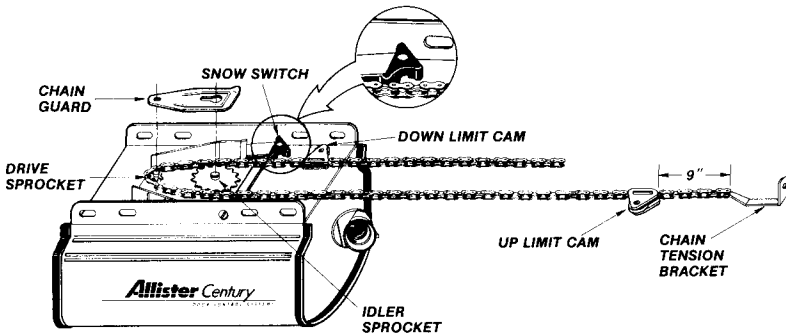
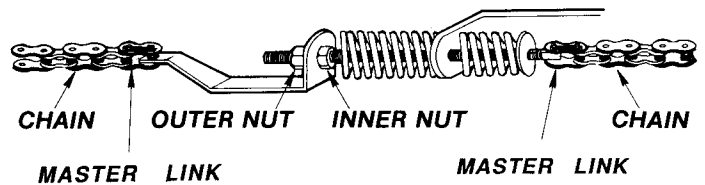

Step 5: Install the limit cams on the chain as illustrated. These settings are temporary and will be changed later toward the completion of the installation.

Make sure the "Snow Switch" is flipped to the position shown. Install the chain guard by sliding the key-shaped hole onto the large idler sprocket and fully seating the rear hole over the drive sprocket.

Assembly is now complete and you are ready to begin installation.

IMPORTANT
BEFORE BEGINNING INSTALLATION,
OBSERVE ALL CAUTIONS LISTED BELOW

*DISABLE LOCK BARS ON GARAGE DOOR

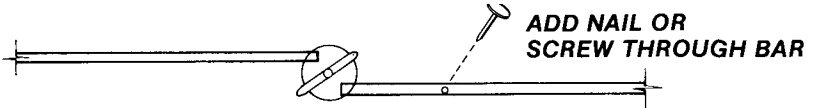

ADD NAIL OR SCREW THROUGH BAR

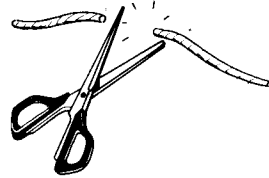
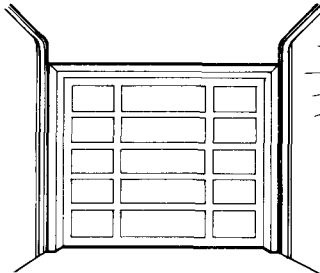

AVOID ENTANGLEMENT
 *REMOVE ALL ROPES ON GARAGE DOOR

*LUBRICATE ALL DOOR HARDWARE
 USE LIGHT OIL OR SILICONE SPRAY

*WEAR SAFETY GOGGLES

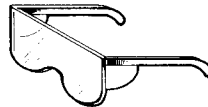

*DO NOT WEAR LOOSE CLOTHING WHILE INSTALLING OPERATOR

*REINFORCE LIGHTWEIGHT DOORS FOR CONNECTING DOOR MOUNTING BRKT.

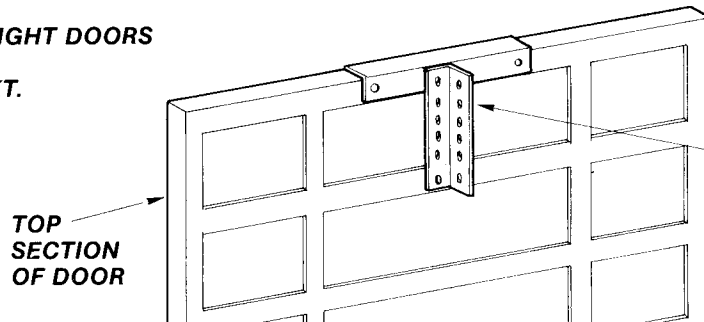

ADD STEEL ANGLE BRACES AS NECESSARY

IMPORTANT
IDENTIFY YOUR DOOR TYPE FROM THOSE ILLUSTRATED BELOW AND FOLLOW INSTRUCTIONS PERTAINING TO THAT TYPE OF DOOR

**SECTIONAL DOOR
 CURVED TRACK
 HIGH ARC OF DOOR TRAVEL**

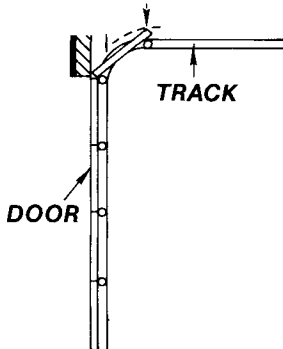

**ONE PIECE DOOR
 HORIZONTAL TRACK
 JAMB HARDWARE
 HIGH ARC OF DOOR TRAVEL**

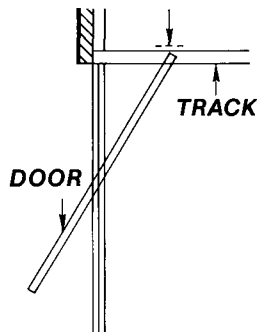

**ONE PIECE DOOR
 NO TRACK
 JAMB HARDWARE
 HIGH ARC OF DOOR TRAVEL**

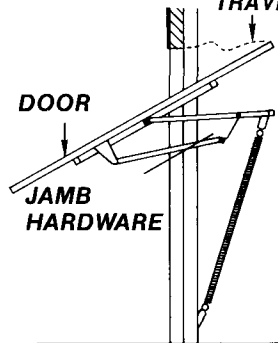

**ONE PIECE DOOR
 NO TRACK
 PIVOT HARDWARE
 HIGH ARC OF DOOR TRAVEL**

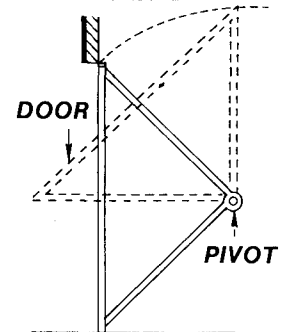

USE 7', 8' OR 10' OPERATOR (MATCH DOOR HEIGHT); USE 1/3 OR 1/2 HP.

USE 6' OPERATOR (FOR DOOR HEIGHT UP TO 8'); 1/3 HP ONLY.

INSTALLATION INSTRUCTIONS

Step 1: Mark a vertical centerline on the header above the door. Raising the door slightly, determine the high arc of the door's travel and, using a level, transfer this measurement to the header. Draw a horizontal line, crossing the previously drawn centerline, at this point. Draw another horizontal line 2" above the high arc line. Install the front mounting bracket securely with lag screws. If necessary, reinforce the header with steel angle iron or wood to insure a secure mount.

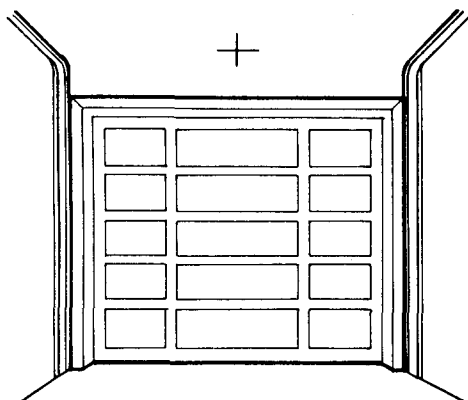

IMPORTANT
INSTALL BRACKET SECURELY

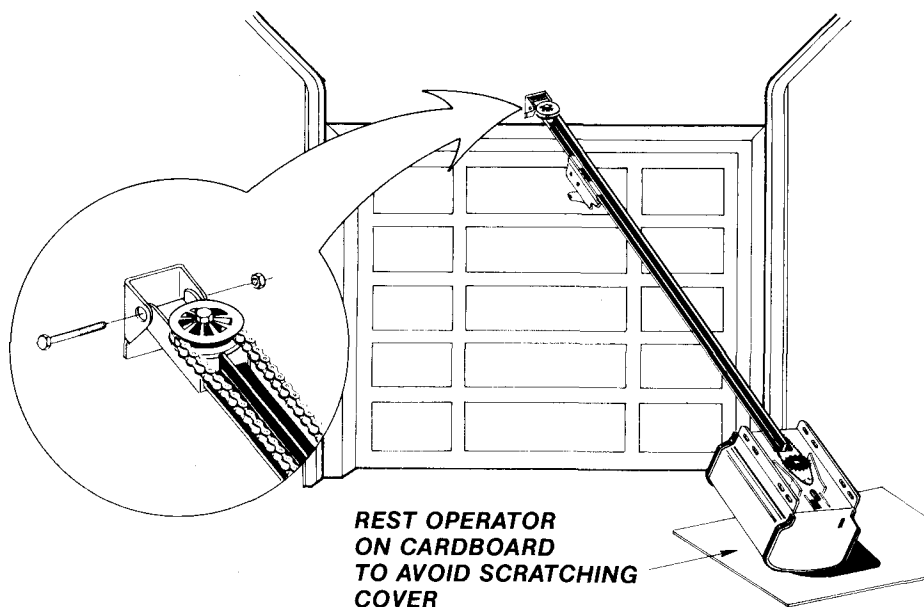
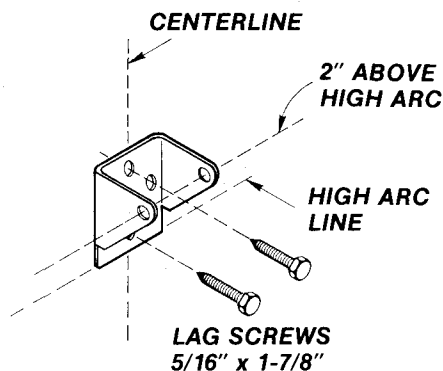

Step 2: Raise the Tee Rail so that the front idler bracket and front mounting bracket align. Insert bolt and tighten nut loosely for now. Later in the installation, this nut must be tightened securely.

Step 3: Raise the operator and rest the Power Unit on a ladder or other sturdy support. Allow 2" of space between the Tee Rail and door. One-piece doors without tracks will have the operator Power Unit angled downward as illustrated. This is necessary for proper operation of the door.

SECTIONAL DOORS AND ONE-PIECE DOORS WITH TRACKS

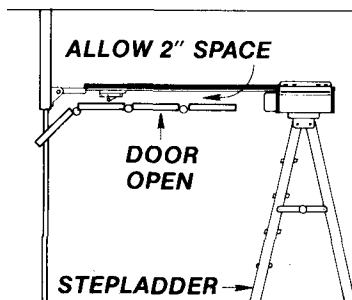

ONE-PIECE DOORS WITHOUT TRACKS

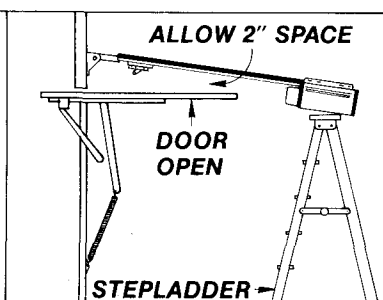

A common installation error is installing the operator too high over the door. If you install the front mounting bracket 2" over the door's high arc of travel and allow a 2" space at the rear you will have a smoothly operating door when the installation is complete. Since the operator will be secured permanently in this position, open and close the door a few times to be sure the door does not rub on the Tee Rail and that you have allowed the proper clearances before proceeding.

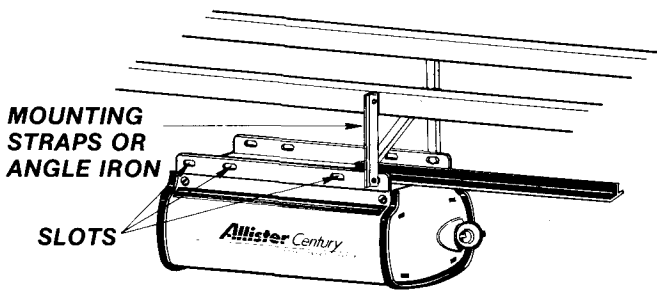

Step 4: Since there is such variety in ceiling structures, all the mounting possibilities for the Power Unit cannot be illustrated here. The main concern is mounting the Power Unit securely to the ceiling joists for operational strength, rigidity and safety. Although there are a series of mounting slots provided on the power unit, **TRY TO SECURE THE MOUNTING STRAPS IN THE SLOTS CLOSEST TO THE FRONT.** Mounting may usually be accomplished using standard 2" perforated steel angle available at most hardware stores. If in doubt about location of and attachment to ceiling joists, a carpenter should be contacted to provide assistance.

Step 5: On sectional doors, install the door mounting bracket on center, and even with the top set of rollers on the door. If the door is of light gauge construction it may be necessary to reinforce the center stile of the door with steel angle or wood to prevent damage to the door if it encounters an obstruction on closing. Connect the upper half of the door arm to the trolley using the clevis pin and clip provided. Connect the curved lower half of the door arm to the door mounting bracket using the self-locking nut and bolt provided. **DO NOT OVERTIGHTEN.** The door arm must pivot freely. Connect the two sections of the door arm with the nuts and bolts provided, adjusting the length of the door arm so that it leans back as illustrated. Do not install the door arm straight up vertically, or the emergency release mechanism will not work smoothly.

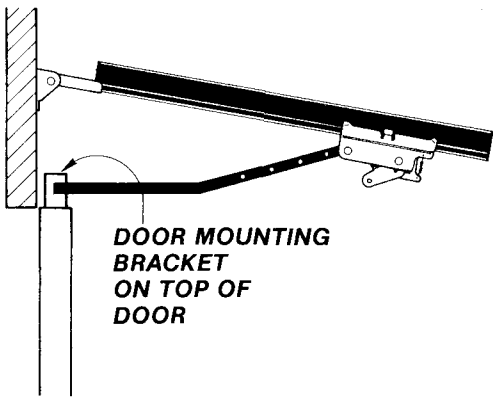
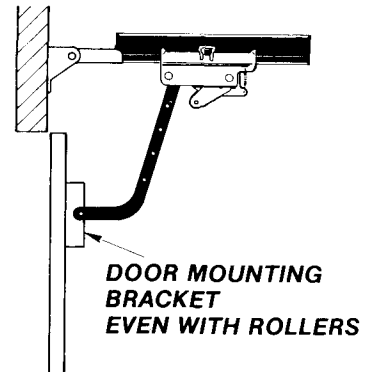

On one-piece doors, the door mounting bracket should be fastened to the top edge of the door, as illustrated.

SECTIONAL DOORS AND ONE-PIECE DOORS WITH TRACKS

ONE-PIECE DOORS WITHOUT TRACKS

IMPORTANT
NOW IS THE TIME TO RETURN TO THE TEE RAIL/FRONT MOUNTING BRACKET BOLT (SEE STEP 2) AND TIGHTEN THE NUT SECURELY.

Step 6: Attach the emergency release rope and handle by slipping the rope through the handle in the release lever and tying an overhand knot. Adjust the rope so that the **RED HANDLE IS 6' ABOVE THE FLOOR.** If the rope must be cut, heat seal the cut end with a match or lighter.

The emergency release mechanism is engaged by pulling the release handle down and away from the door. This allows the trolley mechanism to separate, freeing the door from the operator transport mechanism. To re-engage, simply move the emergency release mechanism lever forward and then operate normally using the pushbutton or radio control. The two parts of the trolley mechanism will automatically reconnect.

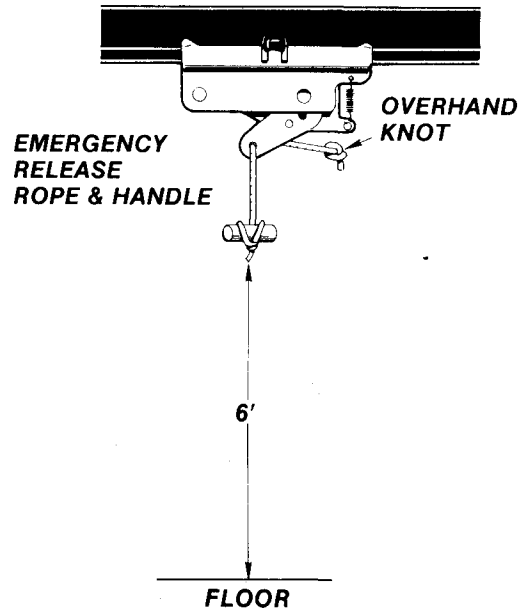

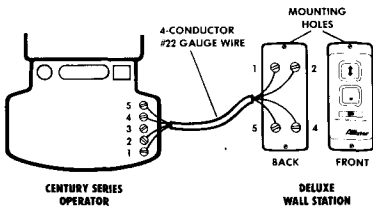
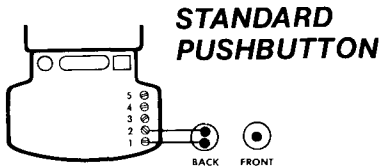

Step 7: Connect a standard pushbutton to Terminals 1 & 2 on the operator rear panel using a length of 2-conductor, 22 gauge wire. If an Allister Deluxe Wall Station is being used, refer to the instructions supplied with that device. For mounting either the standard pushbutton or the Deluxe Wall Station, select a convenient location near an access door. **MOUNT AT LEAST 5' FROM THE FLOOR TO PREVENT SMALL CHILDREN FROM OPERATING THE DOOR.** Install the caution label supplied with the operator near this installation. **ALL WARNINGS SPECIFIED ON THE CAUTION LABEL SHOULD BE STRICTLY ADHERED TO OR SERIOUS PERSONAL INJURY OR DEATH MAY RESULT FROM IMPROPER OPERATION.**

Step 8: Consult the label on the rear panel of the operator to determine its proper working voltage. Normally it will be marked for 115V, 60 cycle operation. (If it is an export model designed for 220V, 50 cycle operation, the label will clearly indicate this.) The door operator must be plugged into a properly grounded receptacle within 3' of the power unit. **A GFI TYPE RECEPTACLE IS RECOMMENDED.** Do not use 2-prong adapters and do not use extension cords for anything more than temporary hook-up and testing purposes. Receptacle wiring should be No. 14 or heavier, and must be in compliance with local building and electrical codes.

If local codes require permanent wiring, a GFI type circuit breaker is recommended to protect the line. Remove the strain relief bushing and withdraw the line cord from the rear of the power unit to expose the three insulated connectors. Cut the wire at the rubber jacket of the line cord and wire in permanently, employing proper wiring practices. Discard strain relief anti-rotation plate, as it is not used with permanent wiring.

Step 9: Install a 60 watt bulb firmly in the light socket. Light bulbs in door operators are subject to vibration during normal operation which may shorten the life span of standard bulbs. Standard bulbs may be replaced with rough service bulbs, available at most hardware stores. Fit light diffuser if supplied (Optional on 310).

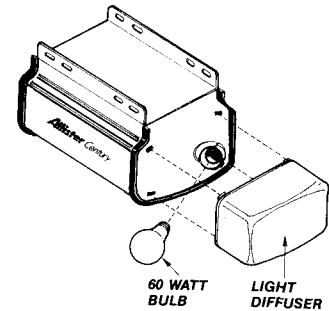

Step 10: If your operator was supplied fully assembled, the limit cams should already be fastened to the chain. If not, fasten the limit cams on the chain in the approximate positions illustrated above..

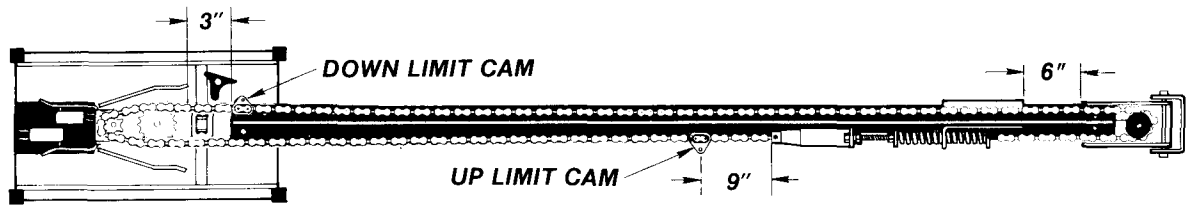

To check limit settings, start the operator running by shorting Terminals 1 & 2 on the operator back panel using an insulated screwdriver or jumper wire. Be prepared to kill the power quickly by pulling the plug if you see that the door will overtravel. Move the cams toward the power unit to decrease door travel, and toward the front idler to increase travel. Adjust the up-limit cam so that the door stops where it would normally come to rest without an electric operator. Adjust the down-limit cam so that the door shuts firmly without putting undue stress on the door arm where it is connected to the garage door. **IF NOT ADJUSTED PROPERLY, THE EMERGENCY RELEASE MECHANISM WILL NOT WORK AND DOOR OPERATION COULD RESULT IN DOOR DAMAGE, SERIOUS PERSONAL INJURY OR DEATH.**

Step 11: Sensitivity System force adjustment screws are located on the side rails of the power unit and can easily be adjusted with a screwdriver. Turn the screws **CLOCKWISE** for more force and **COUNTER-CLOCKWISE** for less force. **TO AVOID THE DANGER OF ENTRAPMENT OR INJURY, SET THESE ADJUSTMENTS FOR JUST ENOUGH FORCE TO OPERATE THE DOOR RELIABLY, BUT NO STRONGER. IF EXCESSIVE FORCE IS REQUIRED TO OPERATE THE DOOR, DISCONNECT THE OPERATOR AND HAVE DOOR OPERATION CHECKED BY AN EXPERIENCED SERVICE PERSON. FAILURE TO DO SO MAY RESULT IN SERIOUS PERSONAL INJURY OR DEATH.**

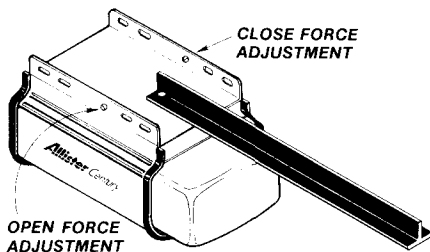

To test the sensitivity system, start the operation and grasp the bottom door handle halfway through the door's travel (opening or closing) If the force adjustment screws are properly set, the door should stop if opening, and reverse if traveling in the close direction.

To test the "Snow Switch" feature, place a solid object 1" thick or less on the ground where the center of the door will contact it. Close the door. If the down force adjustment is correct, door travel should stop and the operator should shut off, rather than reverse during the last 1" of travel.

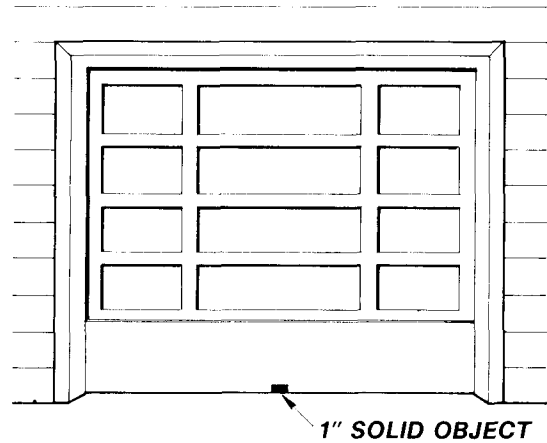

IMPORTANT
THE TESTS OUTLINED IN STEP 11
SHOULD BE PERFORMED MONTHLY TO
ENSURE THAT THIS IMPORTANT SYSTEM
REMAINS IN PROPER ADJUSTMENT.

Step 12: Install radio controls. Note: Some models have an internal radio receiver, others require an external receiver. In either case, THE FACTORY PRE-SET CODES MUST BE CHANGED TO PREVENT UNAUTHORIZED OPERATION. Transmitter and receiver codes must be set identically. If just one code switch is mismatched, the radio controls will not function.

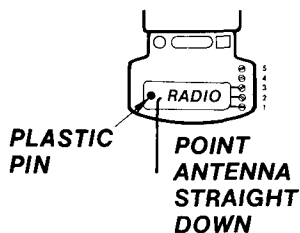

For Allister external receivers, remove the code switch cover on the bottom of the unit to reveal the coding block which consists of nine small switches which can be set in the "On" or "Off" position. Using a small screwdriver set the switches in any arrangement you wish to select. (For example, #1 "On", #2 "Off", #3 "On", etc. Tri-Command radios for three-channel operation use "+", "-" & "0" Do not set all the switches in the same position.) This is your private security code, which must be duplicated on all radio control components. Refer to radio control instructions for more specific information.

After setting the security code, mount the receiver on the rear panel of the operator by connecting it to Terminals 1, 2 & 3. A Small plastic pin is provided to secure the radio receiver firmly to the back

For operators with internal receivers, locate the receiver coding block cut-out on the back panel of the operator. Here the "Up" position is "Off" and the "Down" position is "On". Unplug the operator before setting the code. Note that this block has 10 switches. The #10 switch is not a coding switch. It serves as an "Off/ON" switch for the internal radio receiver. It must be in the "On" position for the radio controls to function.

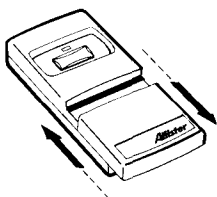

For the transmitter(s), access the coding block by sliding the battery cover panel away from the top of the transmitter. The transmitter may be used hand-held or affixed to your sun visor with the removable visor clip. The transmitter has an LED light(s) to indicate battery condition and give a visual indication that the remote control function has been activated. If this light

gets dim, replace the battery with a standard nine-volt battery (NEDA 1604).

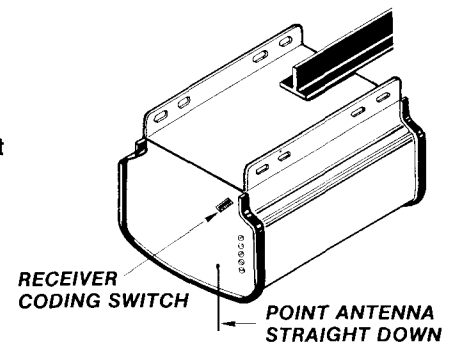

After installing your radio controls, check their operation by moving approximately 50' back from your garage door and pressing the transmitter button. Operation at this distance should be reliable. NEVER OPERATE THE DOOR WHEN YOU CAN'T SEE IT.

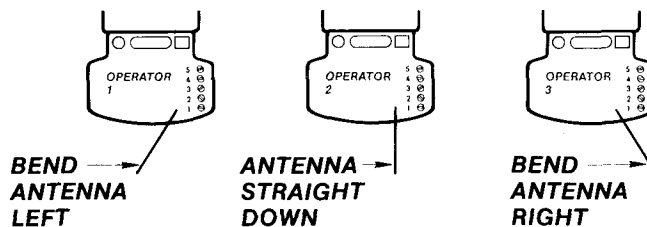

If the transmitter doesn't activate door operation, check that all coding switches are set identically. If the operational distance is inadequate, try moving the position of the transmitter in the car. If the distance is still inadequate, try bending the antenna wire to a different angle. In multi-door applications using separate radio controls, try bending the antennas as illustrated.

ALLISTER CENTURY SERIES TROUBLE SHOOTING

WARNING: USE EXTREME CAUTION AT ALL TIMES WHEN ATTEMPTING TO DIAGNOSE AND RECTIFY PROBLEMS WITH YOUR GARAGE DOOR OPERATOR. BEFORE ATTEMPTING ANY SERVICE ON UNIT, DISCONNECT OPERATOR FROM POWER SUPPLY. YOUR GARAGE DOOR IS THE LARGEST MOVING OBJECT IN YOUR HOUSE, AND THE SPRINGS, PULLEYS, CABLES AND MOUNTING HARDWARE UTILIZED TO BALANCE ITS OPERATION ARE UNDER EXTREME TENSION AT ALL TIMES AND CAN CAUSE SERIOUS PERSONAL INJURY, EVEN DEATH, IF DISTURBED. CALL AN EXPERIENCED SERVICE PERSON TO MOVE, LOOSEN OR ADJUST DOOR SPRINGS OR HARDWARE.

SYMPTOM

PROBABLE CAUSE/SOLUTION

Operator does not activate	(1)(2)(3)(4)(5)(6)(7)(15)
Operates with pushbutton but not with radio control	(8)(9)(21)(22)(23)(7-Models 310/510)
Stops before reaching full Open or Closed position	(3)(5)(6)(10)(11)(12)(13)(14)(23)
Reverses before reaching full Close position	(6)(11)(14)
Reverses after door closes and contacts floor	(16)(17)
Door opens and closes by itself	(3)(12)(18)(23)
Light will not come on	(19)(7)
Light will not turn off after operator runs	(20)(7)
Transmitter has short range	(8)(21)(22)(23)(7-Models 310/510)

PROBABLE CAUSE

SOLUTION

1. Mechanical door lock enabled	1. Disable or remove all door locks.
2. 120 Volt power not present at outlet	2. Check wall switch, fuse, circuit breaker, etc.
3. Broken or shorted pushbutton, wiring or radio receiver(Model 710)	3. Remove pushbutton wiring and radio receiver (Model 710) from the terminal strip on the back panel of the operator. Activate operator by momentarily connecting Terminals 1 & 2 with a test wire. If operator runs, reconnect items one at a time to find defective circuit. Replace.
4. Grid lock on motor control board	4. Unplug operator, then reconnect.
5. Motor thermal overload protector opened	5. Wait 30 minutes for motor to cool, try again.
6. Door jammed due to broken or incorrectly adjusted spring	6. Ensure that door is in a closed position. Activate emergency release mechanism. If operator will run without door attached, contact your Allister garage door professional to repair door.
7. Defective motor control board	7. Contact your local Allister garage door professional.
8. Weak battery in transmitter	8. Replace battery.
9. Coding switches mismatched	9. Reset switches to identical codes (See instructions).
10. Improper placement of limit cams on chain	10. See instructions for proper placement of limit cams.
11. Door obstructed	11. Remove all obstructions from door area.
12. Transmitter button stuck open	12. Check transmitters to see if an indicator light is on at all times. If so, free button from casing.
13. Up sensitivity force improperly adjusted	13. See instructions. Adjust sensitivitiy.
14. Down sensitivity force improperly adjusted	14. See instructions. Adjust sensitivitiy.
15. Bottom of door frozen to ground	15. Activate emergency release, clear away ice.
16. Ice and snow built up under door	16. Clear away ice and snow to allow door to close.
17. Floor risen or sunk from weather change	17. See instructions to reset down limit cam.
18. Someone in area with identical code	18. Reset all radio controls with to new code.
19. Defective or burned out lamp bulb	19. Replace with rough service bulb (60W max.)
20. Accidental push of light button on Deluxe Wall Station	20. Push light button, light should go out. Activate operator, light should remain on for 4.5 minutes and then go out automatically.
21. Radio receiver not receiving signal	21. Ensure that antenna wire from operator is pointing straight down toward the floor.
22. Transmitter location in car	22. Ensure transmitter is clipped to sun visor. If it is clipped to dashboard or in ashtray, etc., range will be diminished.
23. Defective transmitter or receiver	23. Contact your Allister garage door professional.

Allister

DOOR CONTROL SYSTEMS

WIRING SCHEMATIC MODELS 310, 510, 710

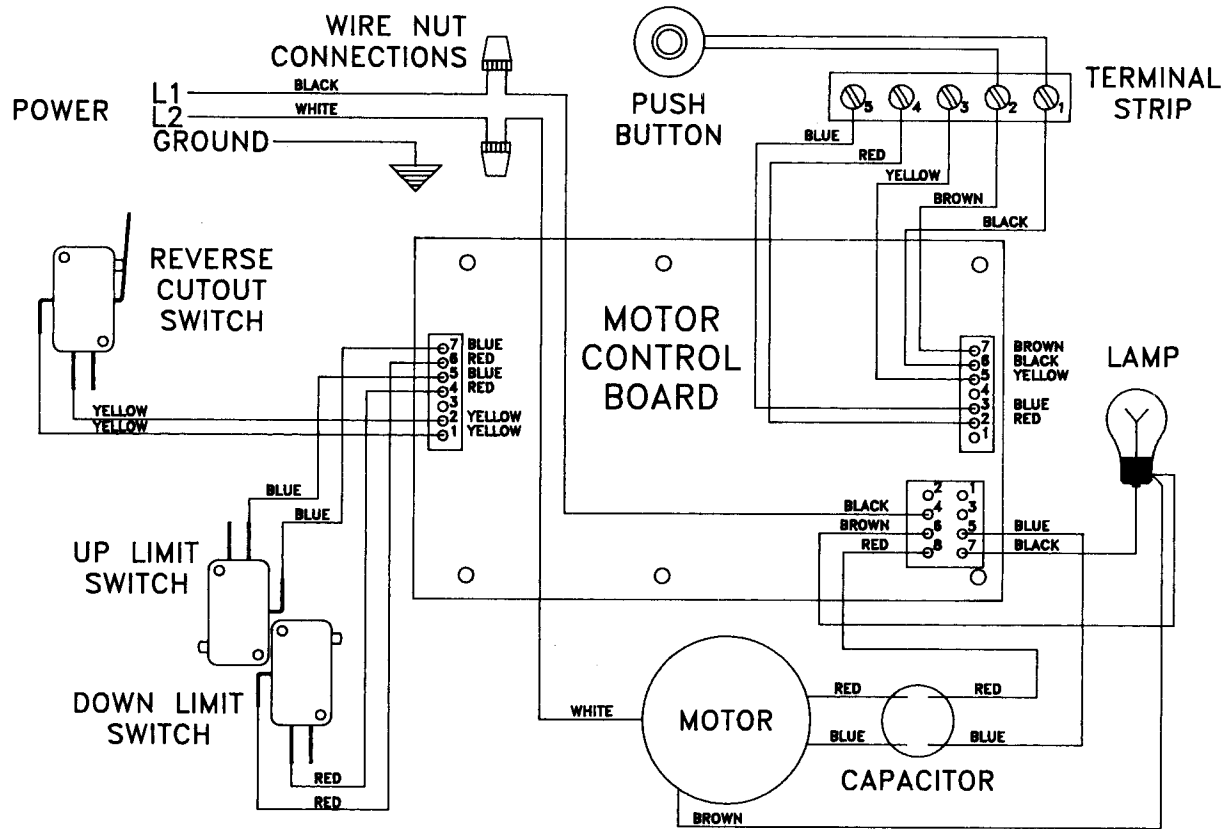

LIMITED WARRANTY

Allister Manufacturing Company, Inc. (the "Company") for a period of one year from date of purchase will repair or replace, at its option, this electric door opener if it fails as a result of defective manufacturing workmanship, subject to the following terms and conditions.

This warranty is made only to the original purchaser of the Company's product. This warranty does not cover any parts or services not provided by the Company and does not cover damage to or misuse, abuse, improper installations, connection to improper power source, fire or lightning, failure to follow the Company's recommended installation and maintenance procedures, or negligence on the part of anyone other than the Company. All work to be performed hereunder shall be rendered by the Company or its designated representatives. The Company will not be responsible for or pay for work performed by anyone other than the Company or its designated representatives. The Company will use, at its discretion, new or factory rebuilt replacements for all repairs. Replacement parts are warranted hereunder only for the remaining, unexpired portion of the original warranty period.

This Warranty is given in lieu of any other express warranty. IN ADDITION, ANY IMPLIED WARRANTIES, INCLUDING WARRANTY OF MERCHANTABILITY ARE LIMITED IN DURATION TO THE TERM OF THIS WRITTEN WARRANTY. Some states do not allow limitations on how long an implied warranty lasts, so this limitation may not apply to you. This warranty does not cover and the Company shall not be responsible for loss of time, inconvenience, property damage, personal injury, or any other incidental or consequential damages. Some states do not allow the exclusion or limitation of incidental or consequential damages, so the above limitation or exclusion may not apply to you.

In order to receive service under this warranty, the defective equipment must be shipped to the Company's plant, F.O.B., at the address listed above along with a complete description of any problem or defect believed to exist. This warranty gives you specific legal rights and you may also have rights which vary from state to state.

INSTALLATION CHECKLIST

BEFORE PLACING DOOR OPERATOR IN REGULAR SERVICE, MAKE SURE THAT:

1. THE FRONT AND REAR MOUNTS FOR THE OPERATOR ARE SOUND AND SECURE AND THAT THE RAIL IS POSITIONED CORRECTLY ABOVE THE HIGH ARC OF THE DOOR, AND THAT THE OPERATOR IS CENTERED OVER THE DOOR ACTION CENTERLINE.
2. THE POSITION OF THE DOOR ARM, WITH THE DOOR CLOSED, IS SUCH THAT ITS CONNECTING POINT ON THE CARRIER IS 5" TO 8" BEHIND ITS CONNECTING POINT ON THE DOOR BRACKET. THE DOOR ARM SHOULD NEVER BE VERTICAL.
3. THE EMERGENCY RELEASE HANDLE AND CORD ARE SECURE TO THE CARRIER RELEASE LEVER. THE HANDLE IS LOCATED 6' ABOVE FLOOR LEVEL AND REQUIRES NO MORE THAN 50 LBS. PULL TO ACTUATE. THE CARRIER AND RELEASE MECHANISM ARE PROPERLY LUBRICATED.
3. THE WALL PUSHBUTTON OR DELUXE WALL STATION IS IN SUCH A POSITION AND OF SUCH A HEIGHT THAT IT CAN ONLY BE ACTUATED BY AN ADULT OF AVERAGE HEIGHT. THE CAUTION LABEL IS PROMINENTLY DISPLAYED NEXT TO THE PUSHBUTTON OR WALL STATION.
5. ALL WIRING IS CORRECT TO CODES OR BETTER. THERE IS GROUND CONTINUITY IN THE SUPPLY. THE GROUND PRONG ON THE POWER CORD IS INTACT.
6. ALL ROPES HAVE BEEN REMOVED FROM THE DOOR. THE DOOR MOVES FREELY WITHOUT BINDING WHEN RAISED OR LOWERED MANUALLY. THE DOOR IS CORRECTLY BALANCED AND LUBRICATED. ALL DOOR HARDWARE IS SECURE AND SOUND. THE SENSITIVITY HAS BEEN ADJUSTED TO MINIMUM FORCE FOR THE APPLICATION. THE APPROPRIATE WARNING STICKER HAS BEEN AFFIXED TO THE DOOR.
7. THE DOOR REVERSES ON OBSTRUCTIONS TO WITHIN 1" OF THE FLOOR. THE CONCRETE OR OTHER SURFACE BENEATH THE CLOSED DOOR PROVIDES UNIFORM CONTACT.
8. THE PLASTIC ENVELOPE FOR THIS MANUAL IS ATTACHED TO THE WALL NEAR THE PUSHBUTTON OR WALL STATION AND THIS MANUAL IS PLACED THERE FOR OWNER USE AND REFERENCE.

ADDITIONAL RECOMMENDATIONS:

1. ON DOORS WITH EXTENSION TYPE COUNTERBALANCE SPRINGS, INSTALL RESTRAINT CABLES THROUGH THE SPRINGS.
2. GFI PROTECTION ON THE LINE TO POWER THE OPERATOR OR IN THE RECEPTACLE. PARTICULARLY IMPORTANT ON INSTALLATIONS INVOLVING DOORS OF STEEL CONSTRUCTION.
3. ON DOORS WITH ADJUSTABLE BOTTOM EDGES, LOCK EDGES AFTER ADJUSTMENT.

Allister Manufacturing Co., Inc.
PO Box 2109
West Chester, PA 19380
