

# MODELS SLC • SLR • SLD

## SLIDE GATE OPERATOR OWNER'S INFORMATION



### IMPORTANT SAFETY INFORMATION AND WARNINGS



The enclosed yellow Safety Precaution literature which accompanies this information is required reading for all users of this system. It is also necessary to read the directives in this packet to familiarize yourself with the proper operation of this equipment. If the information appears incomplete, contact your installing dealer or the manufacturer for a complete packet or explanation before operating this equipment. (OSCO toll-free number 1-800-333-1717)

- This automatic gate is for vehicular traffic only.
- **Children must never be allowed to play on, near or around a motorized gate.**
- Keep all control devices out of the reach of children.
- **Never operate this system without being in sight of the full path of travel of the moving gate!**
- Stand clear of the gate's path of travel at all times. Gate may start without audible warnings. Consult your installing dealer regarding audible/visual pre-start options.
- Never reach between, through or around the gate/fence to access the operator or any control device.
- Turn power off before operating the manual disconnect! A power on/off switch is inside the operator.
- There are no user-serviceable parts inside.
- Do not attempt to make repairs or adjustments to the operator. Call your dealer or a qualified service technician to perform repairs.
- The gate must be maintained properly. If the operator shows signs of increased laboring while moving the gate, or if the gate appears damaged, have it repaired immediately. **TURN POWER OFF AND DISCONNECT THE OPERATOR FROM THE GATE UNTIL THE PROBLEM HAS BEEN CORRECTED.**
- The operator should be tested monthly by a qualified service technician.

*Please read other side*



# IMPORTANT SAFETY INFORMATION AND WARNINGS



## MANUAL DISCONNECT

In the event of power loss or mechanical failure, this slide gate operator is equipped with a manual disconnect lever, located on the top of the frame of the operator. See the illustration at right. Make sure to turn power off before disengaging the operator. **Never disengage the operator while it is running!**

To disengage the operator, pull the disconnect handle away from the front of the operator until the disconnect latch engages. The gate can then be pushed manually to open or close. To re-engage the operator, pull the disconnect latch to the left until the disconnect handle snaps back into its original position. Once the operator is re-engaged, you can reapply power. See the illustration at right for details.

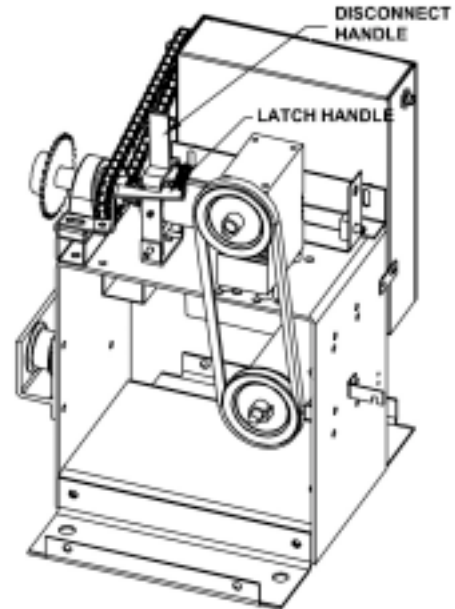

**TURN OFF POWER BEFORE OPERATING THE MANUAL DISCONNECT!**

## GATE OBSTRUCTION SENSING INFORMATION

This operator is equipped with UL325 compliant controls. UL325 requires that each installation have one primary, and at least one secondary obstruction-sensing device. OSCO operators are equipped with a primary current sensing device and contacts for connecting secondary obstruction sensing devices, contact sensor (edge sensor), or non-contact sensor (photo electric-type units).

Any number of access control devices can activate the gate operator. The primary obstruction sensing system and secondary obstruction sensing devices are designed to detect possible entrapment. The installer is required to place sufficient secondary devices to protect the possible pinch points. The installer determines proper location of secondary obstruction sensing devices.

When the primary or secondary sensing devices send a signal before the gate reaches its full open or closed position the gate will **STOP** and **BACK UP**. Another open or close command will activate the gate again. **IF a second obstruction signal** is sensed before the gate reaches its full open or closed position then the gate will **STOP, BACK UP** and sound a **continuous ALARM**.

**IMMEDIATE ATTENTION IS REQUIRED WHENEVER THE CONTINUOUS OBSTRUCTION ALARM IS SOUNDING!**

Check the gate for any obstruction, clear the obstruction, and then push the EMERGENCY STOP/RESET button located on the front of the operator. By pushing the EMERGENCY STOP/RESET button, the gate is now back in operation and awaiting the next command.

Contact your installing dealer or a qualified service technician to perform all adjustments that may become necessary.

OPERATOR SPECIALTY COMPANY, INC. • CASNOVIA, MICHIGAN